

Magnetism

Primary Module
Years 4-7

Science Strand: Energy and Change



Background Information

These sheets are for teachers to use prior to their visits to the GDC. They can be used as information sheets for the students to access or for general information.

Magnets are pieces of special material, which can exert a force on other magnets or magnetic materials. Some magnets are permanent magnets, others can be made magnetic using electric currents, and are called electromagnet: they are made by passing an electric current through a coil.

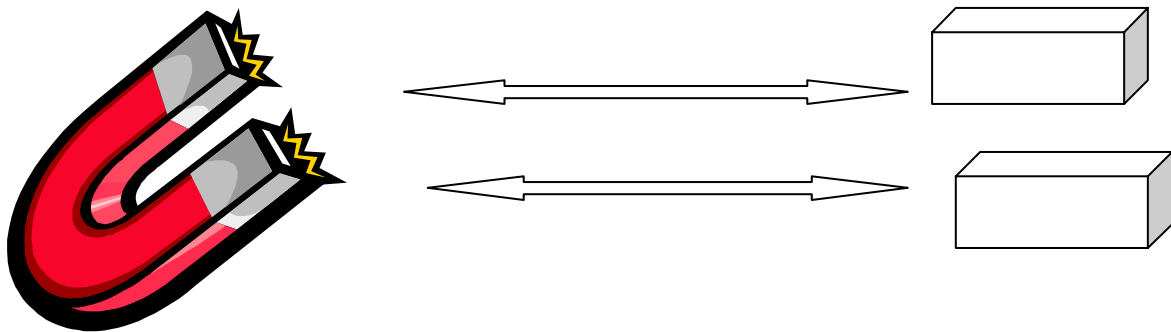

All magnets arise from the motion of electrons. All atoms have electrons in orbits a bit like the orbits of planets in the solar system. In permanent magnets electrons in atoms all orbit in the same direction, like lots of tiny electrons. In an electromagnet the electrons are forced to go round and around like coils of wire.

The world itself is a big magnet. It is thought by scientists that as the Earth rotates, electricity is made in the hot metal deep in the Earth's core. This electricity gives the earth its magnetic field. The Earth has two magnetic poles, called the North Magnetic and South Magnetic Poles. Compass needles always point to the Magnetic North Pole. Students can look up the Internet as to the location of the magnetic North and south poles.

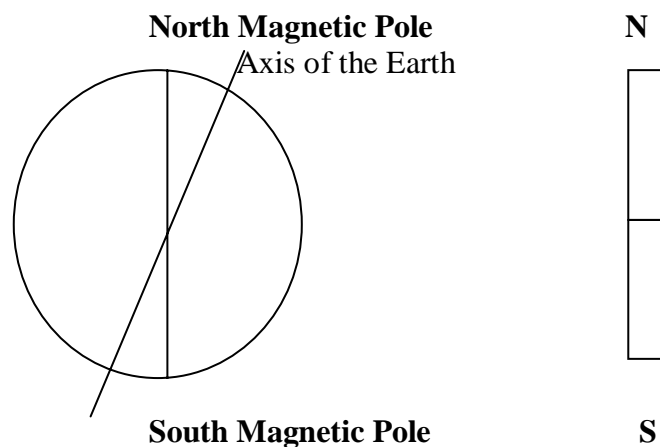

Magnets also occur naturally in the ground. The first magnets were special stones that were found by chance. They were called ‘magic stones’ many centuries ago because they saw that other materials were attracted to it. They also noticed a piece of this stone would point north and south while suspended by a string. The stone could be used as a compass for locating direction.

These stones became known as lodestones. Lodestone, which has been mined for centuries, is a certain type of iron ore that occurs naturally and has the properties of magnets. Iron ore that is magnetic (attracted to a magnet) but does not behave as a magnet is called magnetite. Lodestone is magnetite that behaves like a magnet.

Everyone knows that magnetism is a form of attraction. This is used to hold fridge doors closed and fridge magnets in place. But magnetism is also a force of repulsion: it can cause objects to accelerate apart. Magnetism is a force that can make magnetic objects accelerate away from or, accelerate towards each other.

All matter is made up of tiny atoms. A nail is made up of about a billion, billion iron atoms. Iron atoms are special because its electrons orbit in a way that each atom is quite magnetic. This allows it to be used to make permanent magnets, and also to attract other magnets. To be a permanent magnet all the iron atoms (which are like little magnets) are lined up so permanent magnet it must be made into a very hard alloy that locks all the atoms into place. When the atoms of iron are lined up, so the south poles point in one direction and the north poles in the other, the iron is magnetized.

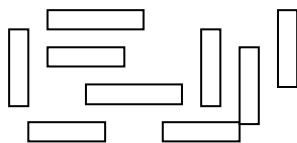

Magnetised Iron

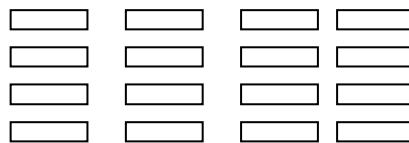

Magnetised Iron

Magnets are attracted to certain materials. We know that magnets have a force field around them that you can see with iron filings. Some materials do not disrupt the pattern of the force field. They are called non-magnetic. Materials that allow a magnetic force field to pass through without any disruptions to the magnetic field are said to be non-permeable. Non-permeable materials are not attracted to magnets. Materials that seem to absorb the magnetic lines of force are said to be permeable. Permeable materials are attracted to a magnet.

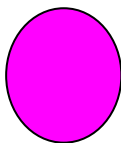

Glass Marble – non-permeable
Non-magnetic

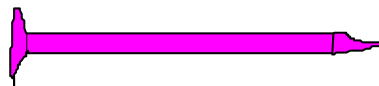

Iron Nail - permeable, magnetic

We also know that magnets have an invisible magnetic field. We know that at the two poles, north and south, the magnetic field is stronger. Both of these poles exert attractive and repulsive forces upon each other. Magnets can repel other magnets when like ends are facing. Magnets can attract other magnets when unlike ends are facing.

Repulsion

N S

S N

Attraction

N S

N S

Moving Magnets – In the 1830's (about the time white settlers were coming to Perth) the British scientist Michael Faraday showed that moving magnets can generate electricity.

This discovery led to the invention of electric generators which now provide some of our electricity. Any time a magnet moves near an electric conductor it makes electric currents. In a generator the conductors are copper wires and these currents get used as electricity. But currents are also produced in solid pieces of metal. These currents cannot be used but they can be felt and they are very dramatic. This module will allow students to explore this remarkable phenomenon.

Teacher Use**Overarching Learning Outcomes** - Curriculum Framework

There are opportunities to assess students in the following outcomes when taking part in this program

- OLO 5: Students describe and reason about patterns structures and relationships in order to understand, interpret, justify and make predictions.
- OLO 6: Students visualise consequences, think laterally, recognise opportunity and potential and are prepared to test options.
- OLO 7: Students understand and appreciate the physical, biological and technical world and have the knowledge and skill to make decisions in relation to it.

Science Learning Area**Working Scientifically**

Investigating and Communicating Scientifically: Students think creatively about how our world works and gather evidence to test their ideas using prediction, observation and measurement.

Understanding Concepts

Energy and Change: Students understand and apply their knowledge about a range of concepts associated with magnetism

Progress Maps - Learning Area : Science

Investigating Scientifically: Students investigate to answer questions about the natural and technological world, using reflection and analysis to prepare a plan; to collect and interpret data; to communicate conclusions; and to evaluate their plan, procedure and findings.

	Level 2 When given a focus question and a familiar situation, contributes elementary ideas about variables and procedures, collects and makes limited records of data and can say whether what happened was expected	Level 3 Shows some awareness for the need for fair testing and makes simple predictions, collects and organises numerical data and descriptive information using simple tables, diagrams and graphs; identifies main features, patterns and difficulties	Level 4 Plans and conducts different types of investigations, taking account of the main variables; collects data using repeat trials or replicates; explains patterns in data or information prepared in different formats; and makes general suggestions for improving the investigation
Aspect 1: Planning - plan investigations to test ideas about the natural and technological world	Identifies, given a focus question, some of the variables to be considered	Plans for investigations, shows some awareness of the for fair testing and makes simple predictions based on personal experience	Identifies the variables to be changed, the variables to be measured and at least one variable to be controlled
Aspect 2: Conducting - collect and record a variety of information relevant to their investigations	Observes, classifies, describes and makes simple non-standard measurements and limited records of data	Uses simple equipment in a consistent manner; records data in simple tables, diagrams or observations	Uses equipment appropriately; recognises the need for safety equipment and precautions; takes care with data collection to ensure accuracy
Aspect 3: Processing Data - translate and analyse information to find patterns and draw conclusions to extend their understandings	Makes comparisons between objects and events observed	Displays numerical data as tables or bar graphs, and identifies patterns in data; summarises the data	calculates averages from repeated trials; plots data as line graphs where appropriate; makes conclusions which summarise and explain patterns in data
Aspect 4: Evaluating Data - reflect on investigation, evaluate the process and generate ideas	Comments on what happened and can determine if what happened was expected	Identifies difficulties experienced in conducting the experiment	Makes general suggestions for improving the investigation

Energy and Change - Students understand the scientific concept of energy and explain that energy is vital to our existence and to the quality of life

Student Outcome statement	Level 2	Level 3	Level 4
	Understands ways that energy is transferred and that people use different types of energy for different purposes	Understands patterns of energy use and some types of energy transfer	Understands that energy interacts differently with different substances and this can affect the use and transfer of energy
Students understand the scientific concepts of energy, give examples of energy sources and describe patterns of energy use around the home and in the community	Students can: describe how another person uses energy in their daily life and list common types of energy	Students can: describe a pattern of energy use at home or school; classify objects as sources or receivers of energy	Students can: compare different sources of energy in terms of their ease of use, cost and effects on living things and the environment
Students understand that energy can be converted from one form into another, and that change involves the transfer of energy	Students can describe a way that energy is transferred and understand that energy moves from one thing to another	Students can: relate the transfer of energy to the carrier and the intended use of that energy	Students can: compare different ways of enabling or impeding the transfer of energy and how different forms of energy transform in different materials.

Teacher Use

The following activities will assist you in understanding some of the concepts of magnetism

1. Finding North - making a compass

You will need: a dish, water, a slice of cork, a needle or a nail, (make sure they are magnetic) and sticky tape.

- Magnetize the needle by rubbing a magnet along it repeatedly in the same direction for 30 seconds. A bit of tapping sometimes helps to jiggle the atoms around into alignment with the magnetic field.
- Tape the needle to the cork and float it in the dish of water. The needle will always point North and South.

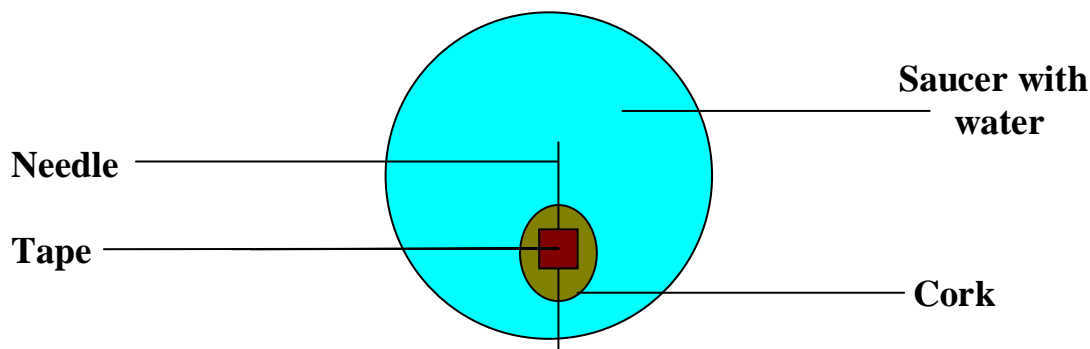

1.1 How will you know if the needle is pointing magnetic North?
(Check with a compass)

1.2 What previous knowledge do you have about magnetism that may be useful?

1.3 Explain what happened. Bring your magnet near the compass and see if it changes.

1.4 What was the result?

1.5 Conclusion:

2. Paper Clip Challenge – *What is happening here: each paper clip is made into a magnet by the action of the magnetic field: the magnetic field is acting to line up all the tiny atom magnets.*

You will need: a magnet, collection of paper clips.

- Have students work in groups using a magnet and paper clips. Students attempt to add as many paper clips to hang in a line from the magnet as they can.

2.1 Record your results in the table below.

Attempt	Number of paper clips
1	
2	
3	
4	
5	

- 2.2 Use strong and weak magnets – magnets come in different strengths - and see how many paper clips the students can pick up.

Magnet	Number of paper clips
1	
2	
3	
4	
5	

3. Attract or Repel – Conduct this experiment on an overhead projector so everybody can see it.

You will need: some bar magnets wrapped in glad wrap, iron filings in salt and pepper shakers, an overhead transparency sheet

- Place the magnets end-to-end but not touching. Place an overhead transparency on top of the magnets.
- Sprinkle some iron filings on the sheet and have students comment on what they see.
- Have a student turn one of the magnets around so again the magnets are end-to-end but not touching. Again, place the sheet of paper on top of the magnets. Sprinkle iron filings on top. Ask students to describe what they see and explain why they think this has happened.
- Now replace one magnet with a nail. See how the nail now acts like a magnet

3.1 What do you predict will happen?

3.2 Write what you observed:

3.3 Can you explain what happened?

Tasks:

1. To observe and use the Magnetic Pendulum, record observations and reach a conclusion.
2. Observe and use the Magnetic Skateboard, introduce variables, record information collected and reach a conclusion consistent with evidence.
3. Observe and use Magnetic Parachute, make predictions, record observations and reach a conclusion.

Materials

You will need:

1. Magnetic Pendulum, aluminium sheet, copper sheet.
2. Magnetic Skateboard, ramp, 1 kg. weights, stopwatch, blocks.
3. Magnetic Parachute, two magnets.
4. Different lengths of clear plastic pipe, stopwatch, copper pipe with viewing holes.

Task 1: Magnetic Pendulum

Magnetic suspension

Rare Earth Magnet Bob

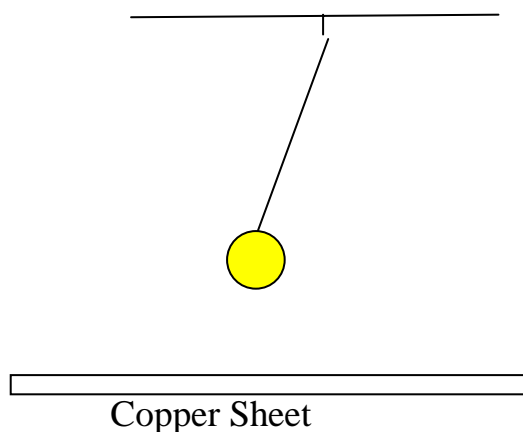

Discuss with students what a pendulum is and why a pendulum is scientifically important - to *provide accurate time keeping, can be used to measure the acceleration due to gravity - 'g' force, and to show that the earth spins.*

- 1.1 Students predict what happens when the pendulum is allowed to swing - *the pendulum swings back and forth. This pendulum will swing for a long time due to its magnetic pivot at A.*
- 1.2 Allow the magnet to swing freely and observe its motion.
- 1.3 Introduce the copper sheet - discuss what the students have observed - *the pendulum stops moving.*
- 1.4 Replace the copper sheet with aluminium. Discuss with students what they have observed.
- 1.5 Discuss where the students think the energy of motion has gone to.
- 1.6 Discuss why the copper plate is warm to touch - *the kinetic energy has been changed into heat energy.*

Task 2: Magnetic Skateboard

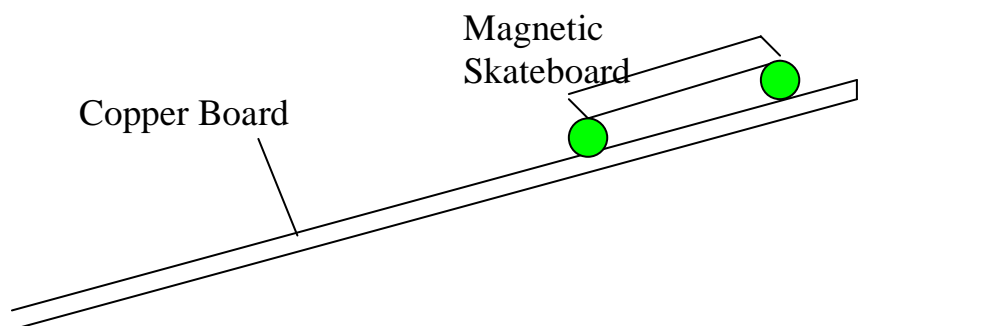

- 2.1 Explain to students the construction of the skateboard ramp.
- 2.2 Students predict what will happen when the skateboard is released.
- 2.3 Students let the skateboard roll down the ramp. Is the reality the same as your prediction?
- 2.4 Students now let the skateboard roll down the plywood sections of the ramp. Is this more like what the students thought would happen?
- 2.5 Students will investigate whether the mass of the skateboard affects the time taken to travel the length of the ramp. Students will add 1kg weights to the

skateboard and record the time. Discuss with students the relationship between mass and time taken.

2.6 Students now keep the skateboard mass constant and increase the slope of the ramp by adding 'blocks'. Discuss the relationship between the time taken and the slope.

2.7 Discuss with students why they think the skateboard behaves in this way.

Task 3: Magnetic Parachute

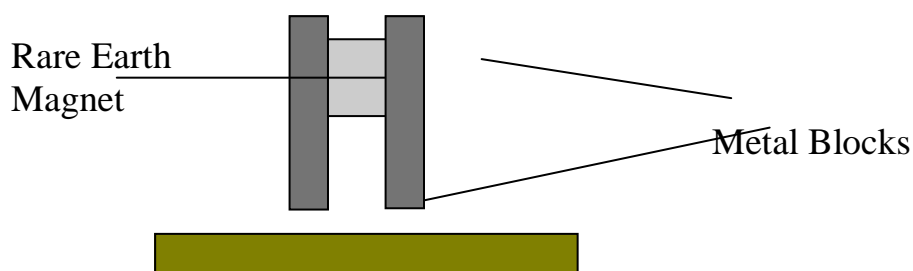

3.1 Explain to students that the magnet will be dropped in the gap between the metal blocks. Discuss what they predict will happen.

3.2 Allow the magnet to fall down between the metal blocks and allow discussion time about the time taken to travel the length of the magnets and the speed of travel.

3.3 Allow the magnet to fall onto a soft landing pad. Observe time taken and speed of travel for this activity in relation to the time and travel through the metal blocks.

3.4 Add another magnet the same size as the first on top of first magnet and let students release them. Students use stopwatch to record time taken and compare to the first magnet drop. Discuss whether weight has any bearing on the time it takes the magnet/s to travel the length of the metal blocks.

Task 4: Magnetic Molasses

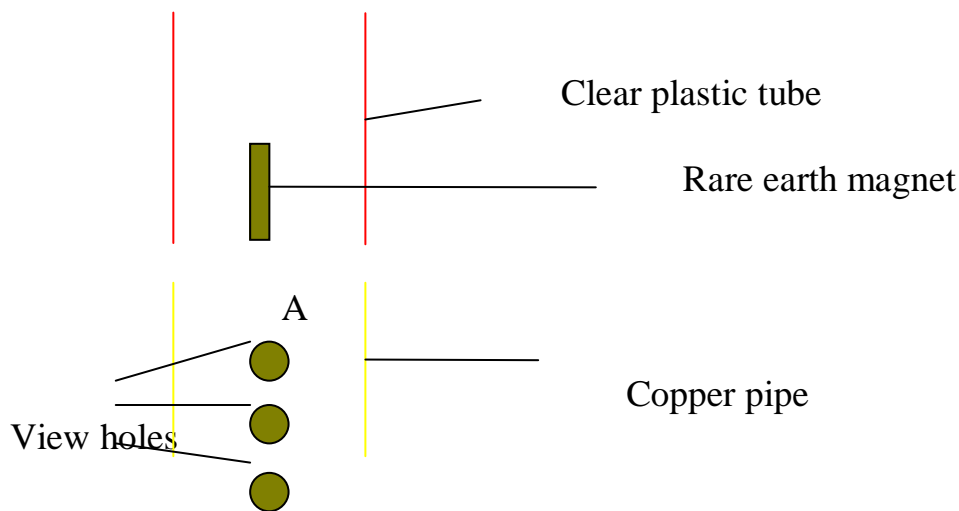

- 4.1 Students estimate how long it will take the magnet to fall through the copper tube.
- 4.2 Students drop the magnet down the copper tube, timing the length of its journey.
Students can view the 'journey' through the viewing holes. Discuss with students what they have seen.
- 4.3 Now using the different lengths of clear plastic pipe investigate if dropping the magnet at different heights affects the 'journey time'. Record observations and conclusion on the worksheet.
- 4.4 Students now tilt the copper pipe and observe what happens when the magnet is dropped.

On-Site Activities

Name: _____

1. What do you think magnetism is? Brainstorm your ideas in the spaces below with a partner.

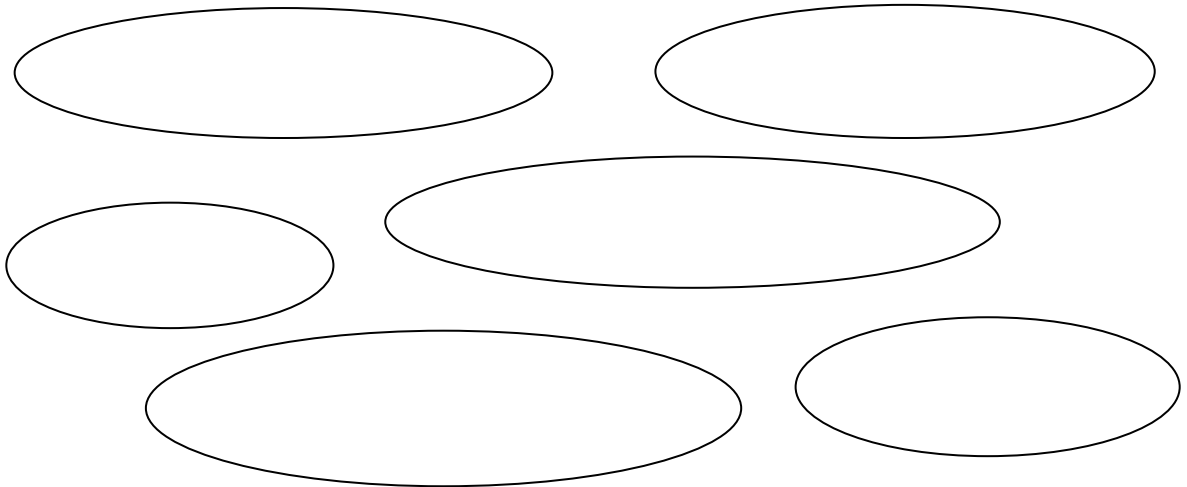
Six empty ovals arranged in a roughly circular pattern, intended for students to brainstorm ideas about magnetism.

2. Why do you think magnets are important?
3. What do you already know about magnets and magnetism?
4. What would you like to find out about magnetism?

Task 1: Magnetic Pendulum

- 1.1 Discuss with your partner/group what a pendulum is and why it is important in our everyday life.

- 1.2 I predict the pendulum will _____
when it is allowed to swing freely.

- 1.3 Observe the pendulum and describe its motion.

- 1.4 Describe what happened when the copper sheet was introduced under the pendulum.

- 1.5 Why do you think this happened?

- 1.6 Where do you think the energy of motion has gone?

- 1.7 How can you prove where the energy of motion has gone?

Task 2: Magnetic Skateboard

2.1 I predict that when the skateboard is released it will ...

2.2 When the skateboard was released it actually ...

2.3 How did your prediction compare to the reality of what the skateboard did?

2.4 Fill in the table below recording times for the skateboard to travel down the ramp and weights added.

Weight (Kg)	Time taken (secs)
1	
2	
3	
4	

2.5 Is there a relationship between weight added and the time taken?

2.6 Did the weights affect the time taken to travel down the ramp?

- 2.7 Remove the weights and now increase the slope of the ramp by adding wooden blocks one at a time. As you add the blocks time how long it takes the skateboard to travel down the ramp. Fill in the table below.

Number of blocks added to increase the slope	Time taken (secs)

- 2.8 Is there a relationship between the slope and the time taken for the skateboard to travel the ramp?

Task 3: Magnetic Parachute

- 3.1 What do you think will happen when the magnet is dropped between the two metal blocks?

- 3.2 Allow the magnet to fall between the metal blocks. What do you observe?

- 3.3 Repeat the last activity - and time the magnets' fall.

The magnet took _____ seconds to fall.

- 3.4 Now let the magnet fall onto the sheet of rubber foam. Time its fall.

- 3.5 Compare the two 'fall' times.
Is there a difference in the time taken for the magnet to fall?

Why do you think this is so?

- 3.6 Use two magnets for this task. Place the magnet between the metal blocks.
Place the second magnet above the first and release.

Time the fall. _____ sec.

Did the time differ from the first drop when you used just one magnet?

Why do you think the time is different?

Task 4: Magnetic Molasses

- 4.1 Estimate how long you think it will take for the magnet to fall down the copper tube.

- 4.2 Working with a partner - one drop the magnet while the other person uses the timer to time the period taken for the magnet to travel the full length of the pipe.

Time taken is _____ secs.

- 4.3 Working with your partner drop the magnet while your partner views the magnet's progress through the copper pipe.
- 4.4 Swap tasks and discuss with your partner what you have seen.
- 4.5 Now using the 4 different lengths of clear plastic pipe investigate whether dropping the magnet at different heights affects the journey time.

Record your observations below.

Height of clear plastic pipe (cm)	Time taken to travel length of pipe (secs)
0	
10	
20	
30	
40	

- 4.6 Working with your partner tilt the copper pipe. One person observes through the 'peep holes' while the other person drops the magnet. Swap tasks.
Discuss what you have seen.
- 4.7 Why do you think this happens?

Teacher Use

During your visit to the GDC the students took part in various experiments involving magnets. The following activities may be useful in consolidating students' understandings of magnetism and magnets.

Some magnets are made by using a current of electricity. These are called electromagnets. Some electromagnets can be very big and powerful. They work when electricity moves along a wire, which is wrapped around a large piece of iron or steel. They can be very useful because they can be turned on and off. They have many uses such as in telephones, refrigerators, power stations, cars and lifting old car bodies to be recycled. Students can try the following activity to demonstrate electromagnets.

1. Find a large nail and wrap a few turns of cotton-covered wire around it. Join both ends of the wire to a torch battery and while the current is flowing try to pick up some small tacks with the electromagnet.

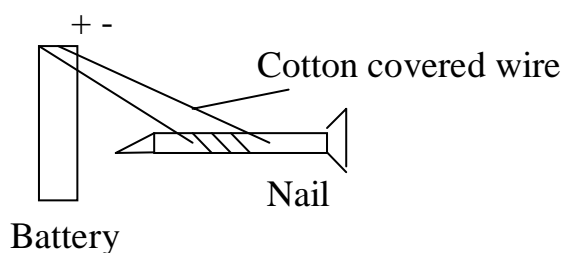

2. Objects such as a plastic comb run briskly through your hair can be charged with static electricity. Just like the poles of a magnet like charges repel and unlike charges attract. If you then hold the comb next to a piece of paper the paper will stick to the comb. The comb is said 'to be charged'. The same can happen when you rub a balloon against your t-shirt and the balloon sticks to you.
Note: *Static electric forces are very closely linked to magnetism. Magnetism is a form of electric force created by moving electric charges.*
3. Blow up two balloons, suspend them from a piece of string. Rub them both with a silk cloth. Have students observe what happens when they are brought close together.

4. Use a plastic ruler or comb and rub vigorously against your shirt or jumper. Hold it close to a trickling tap. Have students observe what happens to the water.

5. There are many books that cover the magnetism topic:
 - 'Picturepedia of Science' A Dorling Kindersley Book 1993
 - 'The Usborne Illustrated Dictionary of Science'. 2001Look in the library to find more.

6. Useful links for science topics:
 - www.usborne-quicklinks.com and follow instructions